

Hermes

PRO MAX Universal Robot Platform

Specification

- Suitable for small and medium sized robot development
- Strong Adaptability
- Widely Modifiable



Contents

I. Introduction.....	3
II. Exterior view	4
III. Charging Dock	5
IV. List of products	5
V. Product parameters.....	6

I. Introduction

Hermes PRO MAX is a compact, adaptive, and cost-effective robot platform developed by SLAMTEC, designed to meet the needs of small robot application development. It can be used in various commercial environments such as intelligent inspection robots, container delivery robots, and restaurant serving robots.

It is equipped with SLAMTEC's newly upgraded high-performance SLAMCUBE2 autonomous navigation and localization system, which enables it to work in various commercial settings with different applications.

Multi-Floor movement and Simple deployment

Hermes PRO MAX is equipped with SLAMTEC's newly upgraded Intelligent Elevator Control System 4.0, which adapts to different elevator deployments from various brands, making it more versatile.

Hermes PRO MAX uses the latest upgraded version of SLAMTEC's RoboStudio 2.0 deployment software, which supports one-click merging of maps for multi-floor mapping. It enhances the mapping and deployment efficiency while streamlining the deployment process, resulting in easy and quick deployment.

Multi-sensor data fusion

Hermes PRO MAX adopts multi-sensor fusion technology, including LiDAR sensor, magnetic sensor, depth camera, collision sensor, ultrasonic sensor, etc. This enables it to adapt freely to the complex and changing commercial environment, and successfully achieve autonomous mapping, localization, and navigation.

II. Exterior view

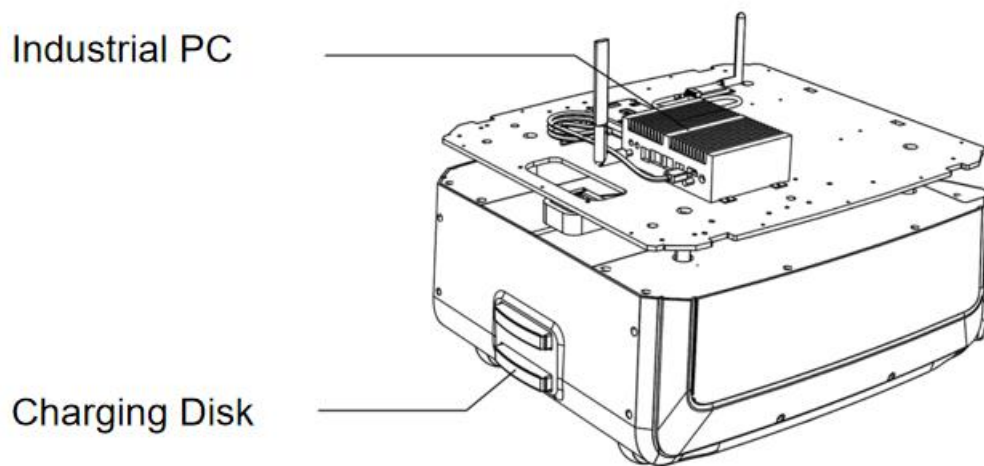
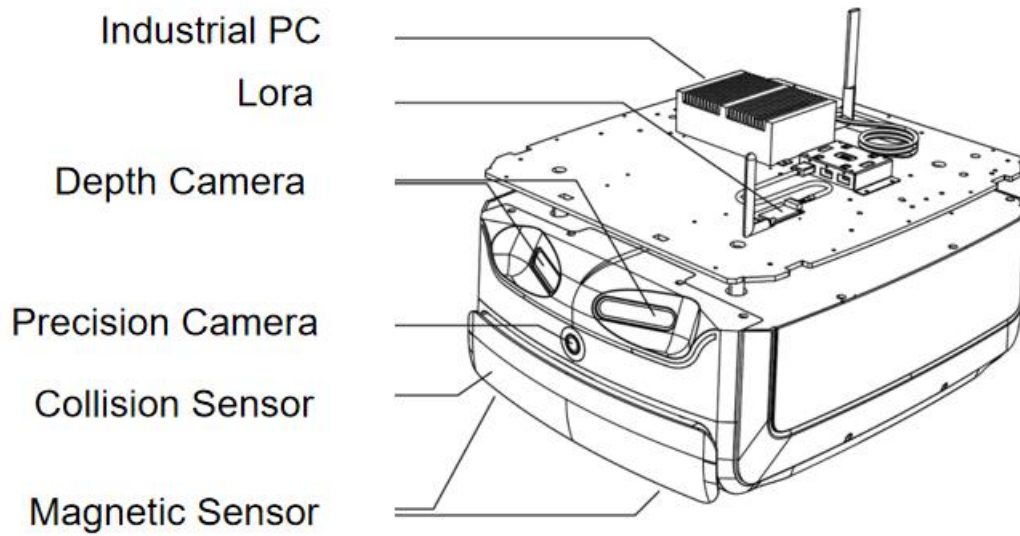

III. Charging Dock

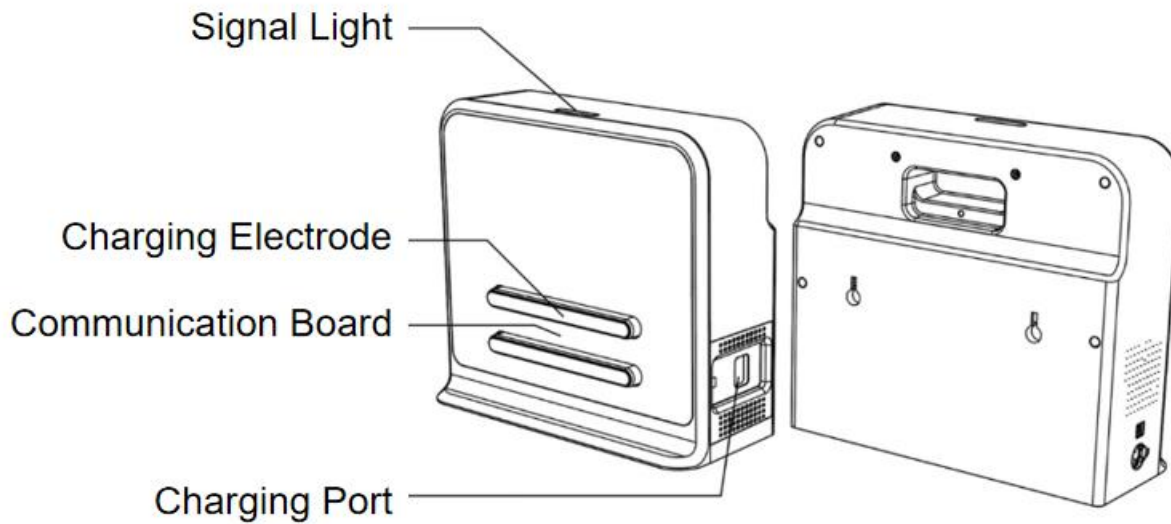

Schematic diagram of charging dock

IV. List of products

Description	Quantity	Remark
Hermes PRO MAX	1	Hermes PRO MAX chassis body
Charging Dock	1	The environment needs to be selected before deployment

V. Product parameters

Product Model		Hermes PRO MAX	
Core Function		SLAMWARE™ Localization and Navigation	
Dimension and Weight		Length*Width	545*465mm
		Height	272mm
		Net Weight	40kg
		Max. Weight Capacity	80kg
Sensor Performance Parameters	Precision Camera (to identify the QR codes)	Docking Accuracy	±1.5cm
		Angle	±1.0°
	LiDAR Sensor	Model	RPLIDAR S2P (Dtof principle)
		Maximum Scanning Radius	0.05-50m (90% reflectivity, white objects) 0.05-10m (12% reflectivity, black objects)
		Ranging Accuracy	±3cm
	Depth Camera Sensor	Quantity	Standard 2(Can be equipped with an additional)
		Detection Range	0.3m - 2m (varies with lighting conditions)
		Field of View (FOV)	H:146.6±3°; V:117±3°
	Magnetic Sensors	Quantity	2
		Maximum Detection Range	3.5cm

	Collision Sensors	Quantity	2
		Trigger Method	physical collision
		Trigger Distance	0.3~0.5cm
		Trigger Force	8N
Mapping Performance	Map resolution	15mm	
	Maximum Mapping Area (Single Build)	500m x 500m (50mm map resolution) 350 x 350m (15mm map resolution)	
	Maximum Operating Area	250,000 m ²	
Movement Parameters	Maximum Travel Speed	1.2m/s (1.5m/s can be customized)	
	Default Travel Speed	0.7m/s	
	Maximum Travel Speed while Mapping	0.6m/s	

Movement Parameters	Maximum Slope Angle	<p>10° Ramp</p> <p>The chassis has a maximum slope angle of 10°, and it can safely navigate slopes with a gradient of up to 18%. The overall height of the vehicle's center of gravity is within 180mm to safely handle slopes of up to 10°.</p> <p>(Note: A slope with a gradient of 100% refers to a 45° incline, where a height difference of 100m</p>
---------------------	---------------------	---

		is covered over a distance of 100m.)
	Traverse Bump Height	20mm
	Minimum Path Width (per wheel)	40mm
	Minimum Path Width (per chassis)	750mm
	Point-to-point Accuracy (AVG)	±20mm (15mm map resolution)
	Point-to-point Accuracy (MAX)	±40mm (15mm map resolution)
	Minimum Point to Angle	±1.0°
	Multi-Robot Obstacle Avoidance	Supports up to 3 robots in the same scene LORA module (standard)
Motor	Wheel Set	2 x 6.5-inch hub motors 4 x 2.5" Universal Wheels

User Interface	Hardware Interface	Power Input	DC 24V 10A
		HDMI	1 x HDMI
		Switch	1 x Brake Release, 1 x Emergency Stop (I/O),

			1 x Power Switch
		Sound	1 x 3.5mm headset socket
			1 x LINE_MIC audio pin (Co-lay with headset socket)
			1 x Bi-Channel 5w/8Ω Amplifier Speaker Pins
	Network Interface	Ethernet	1 x RJ45 Gigabit Ethernet port
		Wi-Fi Band	2.4G/5GHz
	Software Interface	SLAMWARE™	http protocol interface, Can support different development languages and platforms, such as Windows/iOS/Android/Linux
Network	Wi-Fi	2.4G/5G Hz	
	4G	4G SIM for domestic and foreign carriers (paid customization on request)	
Battery Life & Capacity	Capacity	35 AH 18650 Lithium-ion ternary cell (standard)	
	No-load Running Time	>20H	
	Full Load Range	>12H (40kg, room environment)	
	Charging Time	4-5 h	
	Battery life	800 charge/discharge cycles down to 60% of initial capacity	
Power Consumption	Standby Power Consumption	48W (no load)	
	Full Load Power Consumption (Rec. load 40 kg)	75W (moving)	

	Maximum Power Consumption with External Loads	240W
Noise	Noise Level	≤60db
Operating Environment	Operating Temperature	0°C ~ 40°C
	Transportation & Storage Conditions	-25-+55°C
	Operating Humidity	20 ~ 90%rh
	Operating Altitude	≤2000m

Charging Dock	
Overall Dimensions	W360mm*D150mm*H320mm
Color	White
Rated Input	100-240V 50/60Hz 3A MAX
Rated output	DC 25.5V 10A