

Phoebus

Industrial Delivery Robot Platform

Datasheet

Model: P4M11

Easy to use, light deployment/minimal maintenance

Maximum load capacity 300KG

Multi-sensor fusion for 360-degree protection



Phoebus is a small and medium-sized ,scalable industrial delivery robot platform developed by SLAMTEC, designed for small to medium-sized factories. It provides efficient, simple, and reliable automated smart industrial transport solutions, helping end-users improve production processes, enhance productivity, and achieve intelligent transformation and upgrades.

Chassis body

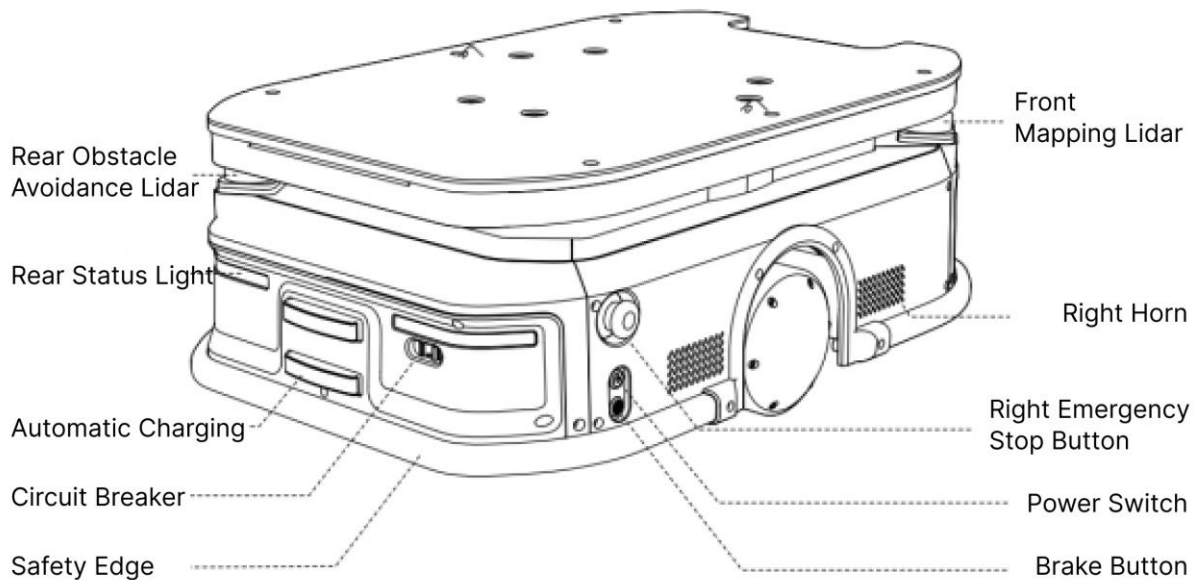
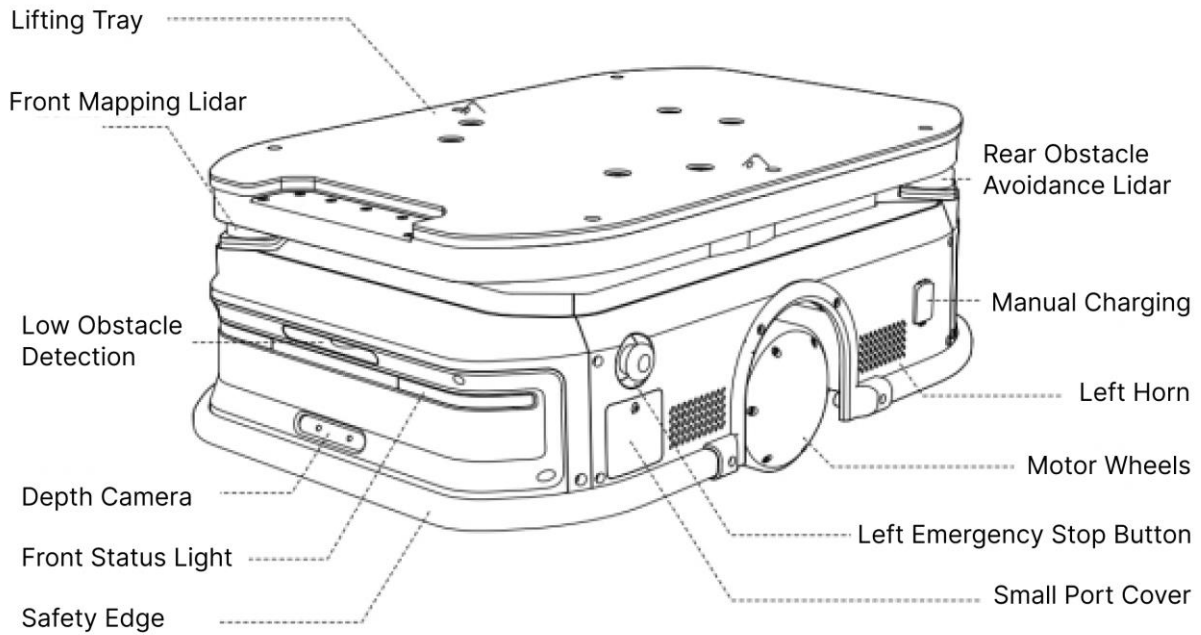

Charging Station

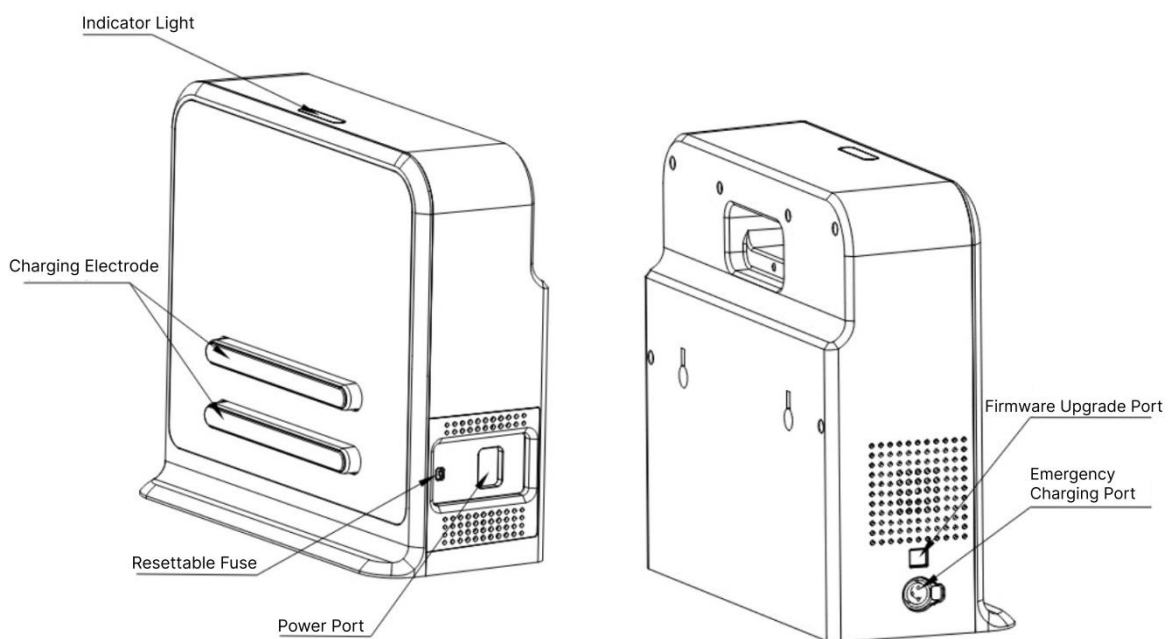

Matching Shelf

Shelf Size L*W*H 700mm*700mm*350mm

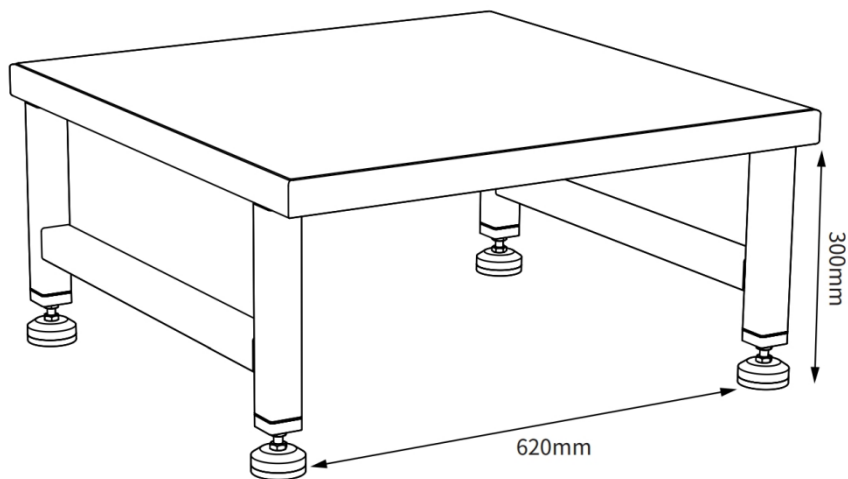

Chassis Basic parameters

Items	Value/Description
Chassis Dimension	780*506*270 mm
Chassis rotation diameter	840 mm
Chassis ground clearance	25 mm
Net weight	≤105 kg
Maximum load	300 Kg
Maximum lifting height	60 mm
Minimum lifting time	4 s
Maximum speed (unloading/loading)	1.5m/s
Maximum speed (fully loaded)	1.2m/s
In-place rotational speed	90°/2s, 180°/3s
Maximum slope/step/Gap	5°/20mm/40mm Under rated load, the full load situation has slightly decreased
Working environment temperature	0~45°C
Battery protect temperature	0~45°C
Navigation to point accuracy	<±40mm, 2°
Endpoint localization accuracy	<±10mm, 1°

Sensor Parameters

Items	Value/Description
Lidar	RPLIDAR S3E, distance 0-40m (90%reflection), accuracy ±3cm
	Quality: 2, diagonal placement
Depth camera	Quality: 1; optional upgrade: 1
	Single Depth camera FOV: H:75±3°; V:51±3°; detect distance: 0.3-3.5m
Front view RGB camera	Optional
VSLAM module	Optional
Low obstacle/cliff detection	1

Industrial Safety Edge Sensor

2

Chassis performance parameters

Items	Value/Description
Driving mode	Two-wheel differential drive
Navigation method	Laser Slam Navigation Visual SLAM (optional)
Map resolution	5cm (default);
Maximum single mapping area	500 m* 500 m (5cm resolution) 300 m* 300 m (1.5cm resolution)
Endpoint localization mode	Support leg Localization method ($\pm 20\text{mm}$, $\pm 2^\circ$) Reflective strip auxiliary localization ($\pm 10\text{mm}$, $\pm 1^\circ$)
Laser SLAM distance	40 m
Battery type	Lithium iron phosphate battery
Battery capacity	30Ah 24V
Battery life	After 2000 complete charge and discharge cycles, the capacity drops to 80% of the initial capacity
Charging method	Manual charging/automatic charging
Running time	12H (no-load operation) 4.5H (typical operating conditions)
Charging time	30~80% 2H
Communication method	4G/WIFI/Lora/Bluetooth
Obstacle detection method	Suspended obstacle detection Low object detection Dynamic and static obstacle detection Cliff detection
Obstacle detection height	Lidar obstacle avoidance: about 180mm (subject to design reference, not exceeding 200mm) Visual/low object avoidance: $\geq 50\text{mm}$ (visual components) (height subject to the plan)

Safety loop	Not supported (dual-charge redundant design protection)	
Status indicator light	Support status light display: steering, abnormal	
Emergency stop switch	2	
Emergency stop impact plate	Omnidirectional package	
Overload & Offset Detection	Not supported	
Machine protection level	IP21	

Chassis button/peripheral interface

Items	Value/description
Power air switch button	Required
Robot power switch	Required
Emergency stop button	Required
Unlock button	Required
Diagnostic interface	Required
Data transmission interface	Required
Reserved interface for code scanner	No
Power supply interface	Yes
Reserved expansion board communication interface	Reserved
Reserved mechanical fixing position	Reserved

Basic parameters of chassis supporting shelves

Item	Value/description
Shelf legs	Adopt ≥ 40 mm square tube (preferably silver, white matte material, etc.)

Minimum shelf size	680*400mm
Maximum shelf size	900*900mm
Standard shelf size	700 * 700 (small)
Shelf bottom height	300mm
Maximum shelf height	1500mm
Height of shelf center of gravity	900mm
Load center of gravity shift	60mm
Cache shelf spacing	The distance between the outermost edge of adjacent shelves is ≥ 150 mm (to be tested, ≥ 200 mm).

Chassis environmental parameters

Items	Value/description
Indoor environment	Indoor scene; Avoid dust, water, fumes, or other pollutants. Stay away from flammable, explosive, or corrosive gases and liquids.
Humidity	10~ 95%, no condensation
Altitude	Below 2000 meters above sea level
Ground cleaning	Keep the floor clean to avoid dust, particles, oil, or liquids.
Ground material	The floor of the robot work area should be made of materials that can release static electricity.
Ground bearing	Hard ground, load-bearing 1.5 tons/square meter, allowable pressure greater than 1.5MPa
Minimum channel width for body passage	600 mm (currently supports 800mm)

Chassis Indicator Light Description

	Items	Light location	Light Status	Light Color
	Power Off	All Chassis Lights	off	/
	Standby	Front or side light strip of chassis	Breathing light	Blue

Chassis	Operation		Front or side light strip of chassis	Solid	Blue	
	Turning		Front or side light strip of chassis	Single Side Flashing	Blue	
	Brake light (TBD)		(If available at the rear)	Flashing during braking, otherwise off	Red	
	Charging		Front or side light strip of chassis	Flashing	Green	
	Fully charged		Front or side light strip of chassis	Solid	Green	
	Discharging		Front or side light strip of chassis	Solid	Yellow	
	Reverse		Front or side light strip of chassis	Flashing	Orange	
	Ambient light		/	/	/	
	Fault	Obstacles blocking passage		Front or side light strip of chassis	Flashing	White
		Machine starting		Front or side light strip of chassis	Solid	White
User Non-Resolvable		Front or side light strip of chassis	Solid	Red		
Emergency stop activated		Front or side light strip of chassis	Solid	Red		
Brake release pressed		Front or side light strip of chassis	Flashing	Yellow		
Charging station	Idle State		Top of Charging station	Solid	Orange	
	Charging		Top of Charging station	Flashing	Green	
	Fault		Top of Charging station	Solid	Red	

Basic parameters of Charging Station

Items	Value/description	Remarks
Dimensions	360*150*320 mm	
Input voltage	200~240V AC, 50Hz±0.4%/60Hz±0.4% 100~120V AC, 50Hz±0.4%/60Hz±0.4%	
Input current	<3A	100-240V 50/60Hz 3A MAX
Input power	350W	

Output maximum current	Input 200~ 240V AC, 25A (adjustable) Input 100~ 120V AC, 15A (adjustable)	
Maximum charging voltage	25.2±0.2V	
Overcurrent protection	>10A	
Over temperature protection	No	
Short circuit protection	Cut off the output	
Leakage protection	Not yet available	
Mode of protection	Protection mode: power off of the whole machine; recovery mode: manual recovery	
Fire prevention measures	Structural components: flame retardant materials improve the protection level, V0 flame retardant Internal wiring: Teflon wire, high temperature resistance, corrosion resistance, strong flame retardancy	The customer's special fire protection requirements involve the renovation period and cost, and need to be communicated clearly in the agreement in advance
Working conditions	Power requirements: The output power of a single charging station power supply should not be less than 2kW. The charging station uses 16A sockets and 25A air switches, each with two sockets. A single charging station uses three 4-square hard wires or cables, trunks, or galvanized pipes. Depending on the number of charging stations, the main line uses 6-10 square hard wires or cables.	Industrial AGV charging station requirements, to be evaluated

Environmental requirements for Charging station

Item	Value/description	Remarks
------	-------------------	---------

Indoor environment	Well-ventilated indoors, away from corrosive gases or flammable and explosive materials	
Operating temperature requirements for charging station (Charging temperature requirements)	0~45°C	
Charging protection temperature	0~45°	Not supported yet, can be customized
Humidity	10~ 95%, no condensation	
Altitude	≤ 2000 m	
Ground cleaning	The floor is clean and free of dust, debris, oil, or liquids.	
Ground material	The ground should be made of materials that can release static electricity.	
Ground flatness	Within 1 square meter, the height difference should not exceed 2mm, and the ground should avoid ditches or steps.	

Charging station indicator light instructions

Process	Prefabrication condition	Indicator light status	Description
Power on and power off	Charging station power on	Red always bright	Indicates that the charging station is powered on normally
	Power off of charging station	Extinguished	Indicates that the charging station is disconnected from the power supply
Automatic charging	Charging station is charging the host	Green slow flash (Breath flickering)	Indicates that the host is charging at the charging station
	Low current charging	Constant green	Indicates that the charging station is charging the robot with a small current

Abnormal state	Charging station fuse abnormality	Red light flashing slowly	Self-recovery fuse ejected, need to press recovery
	Abnormal operation of charging station	Alternating red and green slow flashing	Charging station abnormality or host abnormality (when the host is not in contact with the charging station, it indicates that the charging station is abnormal)